

SSNS100 - Nonlinear behavior of a tablecloth reinforcements under thermal loading

Summary:

A tablecloth of reinforcements not offset compared to the layer average and embedded on its four sides is subjected to a thermal loading. The orientations of the reinforcements are confused with the axes (X, Y) total reference mark.

The principal interest of this test is to validate the digital integration of the models of plastic behavior élasto - GRILLE_ISOT_LINE, GRILLE_CINE_LINE and GRILLE_PINTO_MEN of a tablecloth of reinforcements associated with the finite element GRILLE_EXCENTRE (plate with offsetting compared to the datum-line), in the algorithm general STAT_NON_LINE.

In order to obtain reference solutions, analytical solutions were established for two elastoplastic behaviours with linear and kinematic work hardening isotropic linear. The behavior of Pinto-Menegotto is validated by nonregression of the digital results got with Aster in version 5-3 (cf [§1.3.3]).

1 Problem of reference

1.1 Geometry of the plate

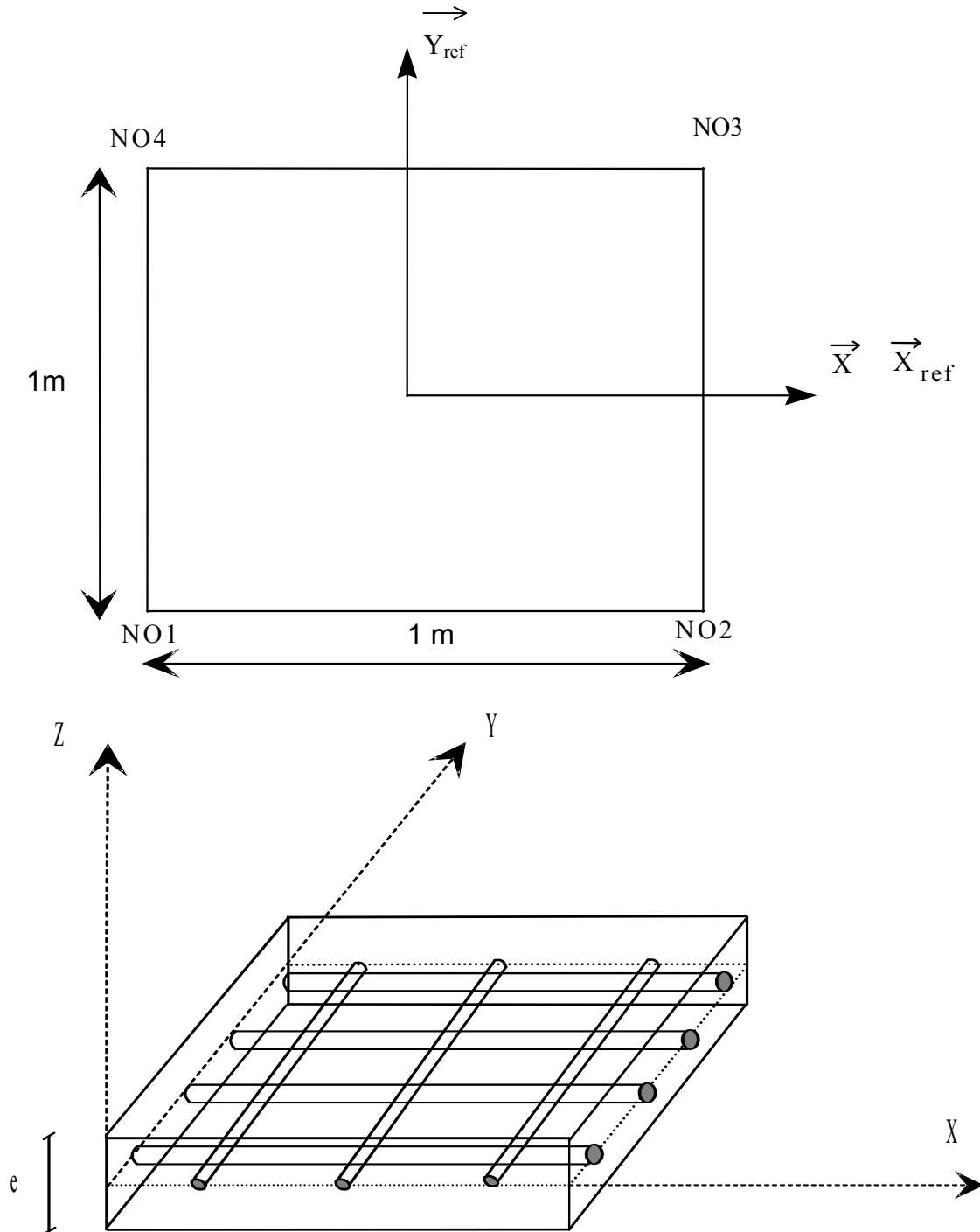

1.2 Characteristics of modelings

This case test is composed of 8 modelings. The table below summarizes their characteristics:

- 1) Orientation of the reinforcements: longitudinal direction (L) : OX ; transverse direction (T) : OY
- 2) Offsetting = $0m$
- 3) Section per linear meter = $0,01m^2/ml$ (even thickness in the directions transversal and longitudinal in the event of presence of transverse reinforcements)

Modeling	Law of behavior	Presence of reinforcement transversal	Mode of application of the temperature
With	isotropic linear	Yes	with the nodes
B	linear kinematics	Yes	with the nodes
C	Pinto Menegotto	Yes	with the nodes
D	Pinto Menegotto	Yes	with the elements
E	Pinto Menegotto	Not	with the elements
F	isotropic linear	Not	with the nodes
G	linear kinematics	Not	with the nodes
H	Pinto Menegotto	Not	***

*** For the case test H, the loading in temperature is replaced by a mechanical loading (displacement imposed on the nodes).

1.3 Properties of materials

1.3.1 Properties common to all modelings

Young modulus: $E = 2.10^{11} MPa$

Poisson's ratio: $\nu = 0$

Elastic limit: $\sigma_y = 2.10^8 MPa$

Thermal dilation coefficient: $\alpha = 10^{-5} (^\circ C^{-1})$

1.3.2 Isotropic and kinematic plastic behavior

For the behaviors isotropic (GRILLE_ISOT_LINE) and kinematics (GRILLE_CINE_LINE)

Slope of work hardening: $E_T = 2.10^{10} MPa$

1.3.3 Behavior of Pinto Menegotto

For behavior PINTO MENEGOTTO (GRILLE_PINTO_MEN)

EPSI_ULTM : $3.0. 10^{-2}$
SIGM_ULTM : $2.58. 10^8$
EPSP_HARD : 0.0023
R_PM : 20.0
EP_SUR_E : 0.01
A1_PM : 18.5
A2_PM : 0.15
DASH : 4.9
A6_PM : 620.0
C_PM : 0.5
A_PM : 0.008

1.4 Boundary conditions and loading

The plate is entirely embedded for modelings A with G (thermomechanical). For modeling H (mechanical), one blocks all displacements and all rotations with the nodes except UX for the nodes $NO2$ and $NO3$.

The loading is of origin thermal for modelings A with G. the change of the temperature according to time is given for each modeling in the following table. The temperature is applied to the nodes or the elements, according to modeling.

Moment	Evolution A T°	Evolution B T°	Evolution C T°
0	50	50	50
1	- 50	- 50	- 300
2	- 250	- 250	- 100
3	- 150	- 150	50
4	- 250	- 250	- 150
5	- 50	- 50	- 350
6	350	350	- 200
7	50	150	
8	- 450	- 450	
9	- 110	- 250	
10	550	650	
11	50	450	

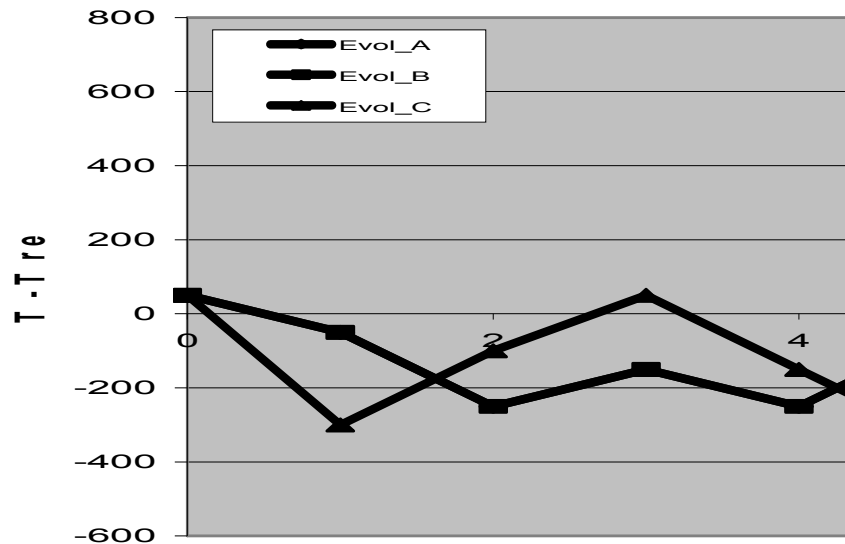

One took for all the tests a temperature of reference of 50° .

For modeling H, one applies a nodal force FX with the nodes $NO2$ and $NO3$ (directed according to the vector UX) by controlling calculation by displacement UX of $NO3$ so that it follows the following evolution:

Moment	0,001	0.0023	0.03	0.2	0.4	6.4	7.92
$U_x (m)$	0,001	0.0023	0.03	0.0296667	0.02	-0.04	-0,033

Moment	17	19	20	21	22	25	50
$U_x (m)$	0.01	0.03	0.0298	0,026	0,022	0,025	0.05

2 Reference solutions

2.1 Isotropic plastic behavior

The reference solution is calculated analytically.

One notes T^+ , ε_p^+ , p^+ , ε^+ the temperature, plastic deformation, cumulated plastic deformation and total deflection at the moment of calculation, and T^- , ε_p^- , p^- same quantities at the previous moment. T_{ref} indicate the temperature of reference.

The solution is calculated in the following way:

$$\sigma_e = E \left[\varepsilon^+ - \alpha(T^+ - T_{ref}) - \varepsilon_p^- \right]$$

$$R(p) = \frac{E \cdot E_T}{E - E_T} p + \sigma_y$$

$$\text{si } |\sigma_e| \leq R(p^-)$$

$$\varepsilon_p^+ = \varepsilon_p^- ; p^+ = p^- ; \sigma^+ = \sigma_e$$

sinon

$$\text{si } \sigma_e > R(p^-)$$

$$\varepsilon_p^+ = \frac{E - E_T}{E} \left[\varepsilon^+ - \alpha(T^+ - T_{ref}) - \frac{\sigma_y}{E} \right] + \frac{E_T}{E} \left[\varepsilon_p^- - p^- \right]$$

$$p^+ = p^- + \varepsilon_p^+ - \varepsilon_p^-$$

$$\sigma^+ = R(p^+)$$

sinon

$$\varepsilon_p^+ = \frac{E - E_T}{E} \left[\varepsilon^+ - \alpha(T^+ - T_{ref}) + \frac{\sigma_y}{E} \right] + \frac{E_T}{E} \left[\varepsilon_p^- + p^- \right]$$

$$p^+ = p^- - \varepsilon_p^+ + \varepsilon_p^-$$

$$\sigma^+ = -R(p^+)$$

This calculation is done in each direction. For the treated case, $\varepsilon^+ = 0$ at any moment.

The constraint memorized in Aster is the real constraint existing in each grid of this direction. Internal variables (ε_p et p) are calculated starting from the equations above.

2.2 Kinematic plastic behavior

The reference solution is calculated analytically.

One notes T^+ , ε_p^+ , ε^+ , X^+ the temperature, plastic deformation and the kinematic variable of work hardening at the moment of calculation, and T^- , ε_p^- , X^- same quantities at the previous moment.

The solution is calculated in the following way:

$$\sigma_e = E \left[\varepsilon^+ - \alpha(T^+ - T_{ref}) - \varepsilon_p^- \right]$$

$$\text{si } |\sigma_e - X^-| \leq \sigma_y$$

$$\left| \begin{array}{l} \varepsilon_p^+ = \varepsilon_p^- ; X^+ = X^- ; \sigma^+ = \sigma_e \end{array} \right.$$

sinon

$$\text{si } \sigma_e - X^- > \sigma_y$$

$$\left| \begin{array}{l} \varepsilon_p^+ = \frac{E - E_T}{E} \varepsilon^+ - \alpha(T^+ - T_{ref}) - \frac{\sigma_y}{E} \\ X^+ = E_T \varepsilon^+ - \alpha(T^+ - T_{ref}) - \frac{\sigma_y}{E} \\ \sigma^+ = E_T \left[\varepsilon^+ - \alpha(T^+ - T_{ref}) \right] + \frac{E - E_T}{E} \sigma_y \end{array} \right.$$

sinon

$$\left| \begin{array}{l} \varepsilon_p^+ = \frac{E - E_T}{E} \varepsilon^+ - \alpha(T^+ - T_{ref}) + \frac{\sigma_y}{E} \\ X^+ = E_T \varepsilon^+ - \alpha(T^+ - T_{ref}) + \frac{\sigma_y}{E} \\ \sigma^+ = E_T \left[\varepsilon^+ - \alpha(T^+ - T_{ref}) \right] - \frac{E - E_T}{E} \sigma_y \end{array} \right.$$

This calculation is done in each direction. For the treated case, $\varepsilon^+ = 0$ at any moment.

The constraint memorized in *Aster* is the real constraint existing in each grid of this direction.

2.3 Behavior Pinto Ménégotto

The reference solution is that obtained by a calculation *Aster* with the same grid to which one applies cycles of load/discharge, in imposed displacement, allowing to recreate the deformations resulting from thermomechanical calculations presented hereafter. The test corresponding is thus only one test of nonregression, by comparing the constraints obtained by these two types of modeling: on the one hand mechanical, and on the other hand thermomechanical.

The constraint memorized in *Aster* is the real constraint existing in each grid of this direction.

3 Modeling A

The test-tube is with a grid with two elements TRIA3 with three nodes for all modelings.

- 2 elements grids to model fibres in the direction OX
- 2 elements grids to model fibres in the direction OY

The nodes of the elements are common for each tablecloth of reinforcement.

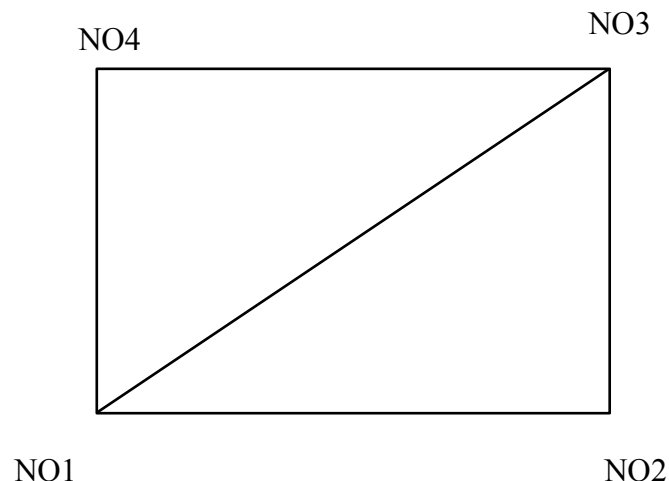

3.1 Results modeling A (linear isotropic work hardening)

3.1.1 Thermal loading for modeling A

Temperature of reference: 50
History of the loading: $Evolution_A$ (cf [§1.4])
The temperatures returned like a field to the nodes.

3.1.2 Results

One belongs to the values to $SIXX$ with the node NOI (in the direction of the longitudinal reinforcements) and $SIXX$ with the node NOI (in the direction of the transverse reinforcements) and those of the Maximum and minimum of the internal variables $V1$ and $V3$.

SIXX in the meshes modelling fibres
directed according to OX

SIXX in the meshes modelling fibres
directed according to OY

Moment	Reference	Code_Aster	Variation	Reference	Code_Aster	Variation
1	2,0000E+08	2,0000E+08	0	2,0000E+08	2,0000E+08	0
2	2,4000E+08	2,4000E+08	0	2,4000E+08	2,4000E+08	0
3	4,0000E+07	4,0000E+07	0	4,0000E+07	4,0000E+07	0
4	2,4000E+08	2,4000E+08	0	2,4000E+08	2,4000E+08	0
5	-1,6000E+08	-1,6000E+08	0	-1,6000E+08	-1,6000E+08	0
6	-3,1200E+08	-3,1200E+08	0	-3,1200E+08	-3,1200E+08	0
7	2,8800E+08	2,8800E+08	0	2,8800E+08	2,8800E+08	0
8	4,0960E+08	4,0960E+08	0	4,0960E+08	4,0960E+08	0
9	-2,7040E+08	-2,7040E+08	0	-2,7040E+08	-2,7040E+08	0
10	-5,2768E+08	-5,2768E+08	0	-5,2768E+08	-5,2768E+08	0
11	4,7232E+08	4,7232E+08	0	4,7232E+08	4,7232E+08	0

Moment	Internal variables	Minimum		Maximum	
		Code_Aster	Reference	Code_Aster	Reference
1	V1	0	0	0	0
	V3	0	0	0	0
2	V1	1.8E-03	1.8E-03	1.8E-03	1.8E-03
	V3	1.8E-03	1.8E-03	1.8E-03	1.8E-03
3	V1	1.8E-03	1.8E-03	1.8E-03	1.8E-03
	V3	1.8E-03	1.8E-03	1.8E-03	1.8E-03
4	V1	1.8E-03	1.8E-03	1.8E-03	1.8E-03
	V3	1.8E-03	1.8E-03	1.8E-03	1.8E-03
5	V1	1.8E-03	1.8E-03	1.8E-03	1.8E-03
	V3	1.8E-03	1.8E-03	1.8E-03	1.8E-03
6	V1	5.04E-03	5.04E-03	5.04E-03	5.04E-03
	V3	5.04E-03	5.04E-03	5.04E-03	5.04E-03
7	V1	5.04E-03	5.04E-03	5.04E-03	5.04E-03
	V3	5.04E-03	5.04E-03	5.04E-03	5.04E-03
8	V1	9.432E-03	9.432E-03	9.432E-03	9.432E-03
	V3	9.432E-03	9.432E-03	9.432E-03	9.432E-03
9	V1	9.432E-03	9.432E-03	9.432E-03	9.432E-03
	V3	9.432E-03	9.432E-03	9.432E-03	9.432E-03
10	V1	1.47456E-02	1.47456E-02	1.47456E-02	1.47456E-02
	V3	1.47456E-02	1.47456E-02	1.47456E-02	1.47456E-02
11	V1	1.47456E-02	1.47456E-02	1.47456E-02	1.47456E-02
	V3	1.47456E-02	1.47456E-02	1.47456E-02	1.47456E-02

Note:

The results presented are given in the reference mark of reference (X_{ref}, Y_{ref}) forming an angle of 0° compared to (X, Y) .

The case studied test corresponds to the following diagram in a plan forced deformation:

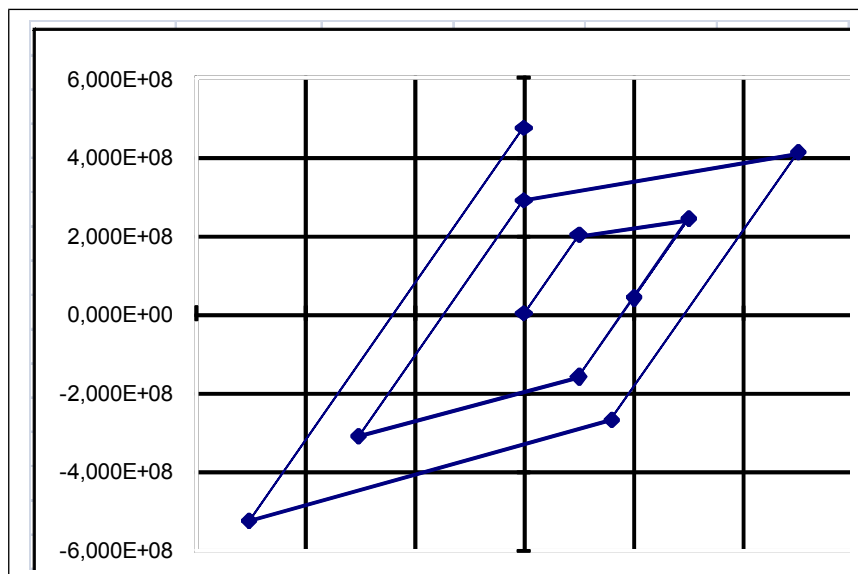

4 Modeling B

Case with linear kinematic work hardening.

4.1 Thermal loading for modeling B

Temperature of reference: 50°C

History of the loading: $Evolution_B$ (cf [§1.4])

The temperatures returned like a field to the nodes.

4.2 Results

One records the values of $SIXX$ with the node NOI (direction of the longitudinal reinforcements) and $SIXX$ with the node NOI (direction of the transverse reinforcements)

Moment	$SIXX$ in the meshes modelling fibres directed according to OX			$SIXX$ in the meshes modelling fibres directed according to OY		
	Reference	Code_Aster	Variation	Reference	Code_Aster	Variation
1	2,00E+08	2,00E+08	0	2,00E+08	2,00E+08	0
2	2,40E+08	2,40E+08	0	2,40E+08	2,40E+08	0
3	4,00E+07	4,00E+07	0	4,00E+07	4,00E+07	0
4	2,40E+08	2,40E+08	0	2,40E+08	2,40E+08	0
5	-1,60E+08	-1,60E+08	0	-1,60E+08	-1,60E+08	0
6	-2,40E+08	-2,40E+08	0	-2,40E+08	-2,40E+08	0
7	1,60E+08	1,60E+08	0	1,60E+08	1,60E+08	0
8	2,80E+08	2,80E+08	0	2,80E+08	2,80E+08	0
9	-1,20E+08	-1,20E+08	0	-1,20E+08	-1,20E+08	0
10	-3,00E+08	-3,00E+08	0	-3,00E+08	-3,00E+08	0
11	1,00E+08	1,00E+08	0	1,00E+08	1,00E+08	0

Note:

The results presented are given in the reference mark of reference (X_{ref}, Y_{ref}) forming an angle of 0° compared to (X, Y) .

The case studied test corresponds to the following diagram in a plan forced deformation:

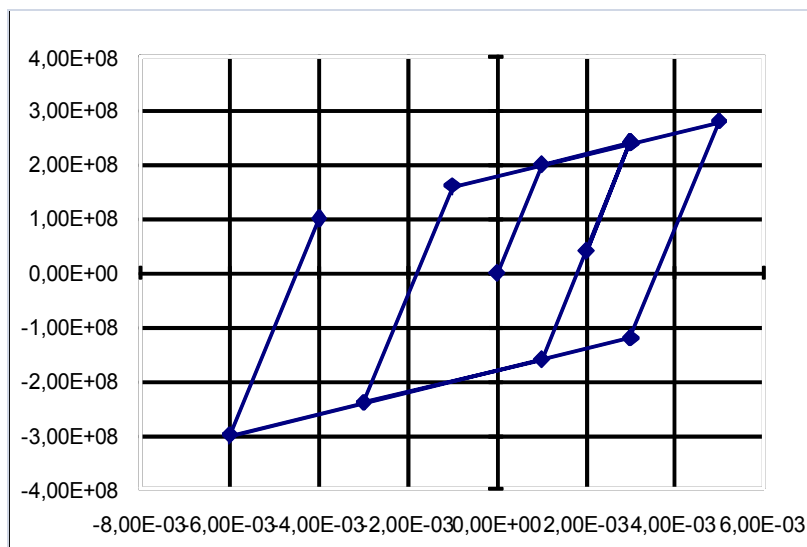

5 Modeling C

Case models of Pinto-Menegotto.

5.1 Thermal loading for modeling C

Temperature of reference: 50°C

History of the loading: $Evolution_C$ (cf [§1.4])

The temperatures returned like a field to the nodes.

5.2 Results

One records the values of $SIXX$ with the node NOI (direction of the longitudinal reinforcements) and $SIXX$ with the node NOI (direction of the transverse reinforcements)

Momen t	$SIXX$ in the meshes modelling fibres directed according to OX			$SIXX$ in the meshes modelling fibres directed according to OY		
	Reference	Code_Aster	Variation	Reference	Code_Aster	Variation
1	2.09416E+08	2.09416E+08	0	2.09416E+08	2.09416E+08	0
2	– 1.21555E+08	– 1.21555E+08	0	– 1.21555E+08	– 1.21555E+08	0
3	– 1.82862E+08	– 1.82862E+08	0	– 1.82862E+08	– 1.82862E+08	0
4	1.52164E+08	1.52164E+08	0	1.52164E+08	1.52164E+08	0
5	2.02506E+08	2.02506E+08	0	2.02506E+08	2.02506E+08	0
6	– 7.59307E+07	– 7.59307E+07	0	– 7.59307E+07	– 7.59307E+07	0

Note:

The results presented are given in the reference mark of reference (X_{ref}, Y_{ref}) forming an angle of 0° compared to (X, Y) .

The case studied test corresponds to the following diagram in a plan forced deformation:

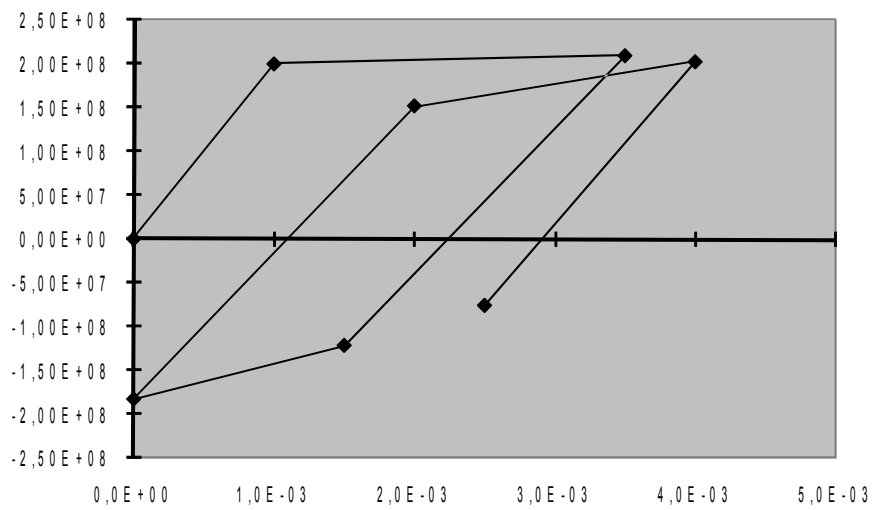

6 Modeling D

Modeling D is the same one as modeling C, with the difference which the temperatures are defined by a map.

The results are identical.

7 Modeling E

Modeling E approaches modeling D, with the difference that there is no transverse reinforcement.

7.1 Results

One records the values of $SIXX$ with the node NOI (not of test on $SIYY$ in the absence of transverse reinforcements because the constraints are only calculated in the principal direction of the reinforcements)

$SIXX$			
Moment	Reference	Code_Aster	Variation
1	2.09416E+08	2.09416E+08	0
2	- 1.21555E+08	- 1.21555E+08	0
3	- 1.82862E+08	- 1.82862E+08	0
4	1.52164E+08	1.52164E+08	0
5	2.02506E+08	2.02506E+08	0
6	- 7.59307E+07	- 7.59307E+07	0

Note:

The results presented are given in the reference mark of reference (X_{ref}, Y_{ref}) forming an angle of 0° compared to (X, Y) .

8 Modeling F

Modeling F approaches modeling A, with the difference that there is no transverse reinforcement.

8.1 Results

One records the values of $SIXX$ with the node NOI (not of test on $SIYY$ in the absence of transverse reinforcements)

SIXX

Moment	Reference	Code_Aster	Variation
1	2.00000E+08	2.00000E+08	0
2	2.40000E+08	2.40000E+08	0
3	4.00000E+07	4.00000E+07	0
4	2.40000E+08	2.40000E+08	0
5	- 1.60000E+08	- 1.60000E+08	0
6	- 3.12000E+08	- 3.12000E+08	0
7	2.88000E+08	2.88000E+08	0
8	4.09600E+08	4.09600E+08	0
9	- 2.70400E+08	- 2.70400E+08	0
10	- 5.27680E+08	- 5.27680E+08	0
11	4.72320E+08	4.72320E+08	0

Note:

The results presented are given in the reference mark of reference (X_{ref}, Y_{ref}) forming an angle of 0° compared to (X, Y) .

9 Modeling G

Modeling G approaches modeling B, with the difference that there is no transverse reinforcement.

9.1 Results

One records the values of *SIXX* with node *NOI* (not of test on *SIYY* in the absence of transverse reinforcements)

SIXX

Moment	Reference	Code_Aster	Variation
1	2,00E+08	2,00E+08	0
2	2,40E+08	2,40E+08	0
3	4,00E+07	4,00E+07	0
4	2,40E+08	2,40E+08	0
5	- 1,60E+08	- 1,60E+08	0
6	- 2,40E+08	- 2,40E+08	0
7	1,60E+08	1,60E+08	0
8	2,80E+08	2,80E+08	0
9	- 1,20E+08	- 1,20E+08	0
10	- 3,00E+08	- 3,00E+08	0
11	1,00E+08	1,00E+08	0

Note:

The results presented are given in the reference mark of reference (X_{ref}, Y_{ref}) forming an angle of 0° compared to (X, Y) .

10 Modeling H

Modeling H is purely mechanical (application of a nodal force on *NO2* and *NO3*). It is here about a case test of nonregression.

10.1 Results

One records the values of: *SIXX* with the node *NO2*
- *EXX* with the node *NO2*

Momen t	<i>SIXX</i>			<i>EXX</i>		
	Reference	Code_Aster	Variation	Reference	Code_Aster	Variation
0,001	2E+08	2E+08	0	1E-03	1E-03	0
0.0023	2E+08	2E+08	0	2.3E-03	2.3E-03	0
0.03	2.58E+08	2.58E+08	0	3rd-02	3rd-02	0
0.2	1.93156E+08	1.93156E+08	0	2.96667E-02	2.96667E-02	0
0.4	-1.43311E+08	-1.43311E+08	0	2nd-02	2nd-02	0
6.4	-2.77424E+08	-2.77424E+08	0	4th-02	4th-02	0
7.92	1.01029E+08	1.01029E+08	0	-3.3E-02	-3.3E-02	0
17	2.1647E+08	2.1647E+08	0	1E-02	1E-02	0
19	2.571E+08	2.571E+08	0	3rd-02	3rd-02	0
20	2.17745E+08	2.17745E+08	0	2.98E-02	2.98E-02	0
21	-8.0318E+07	-8.0318E+07	0	2.6E-02	2.6E-02	0
22	-1.28487E+08	-1.28487E+08	0	2.2E-02	2.2E-02	0
25	2.04332E+08	2.04332E+08	0	2.5E-02	2.5E-02	0
50	2.97691E+08	2.97691E+08	0	5th-02	5th-02	0

11 Summary of the results

For elastoplastic behaviours with linear work hardening, the analytical solution is found perfectly.

The behavior of Pinto-Menegotto is validated by nonregression.