

Macro-order CALC_GP

1 Goal

The object of this macro-order is to calculate, in postprocessing of a calculation of nonlinear mechanics elastoplastic, the called parameter of energy breaking process G_p . The energy approach based on this criterion is detailed in the document [R7.02.16].

This macro-order is usable in 2D and 3D.

In 2D, it makes it possible to use the approach with a specific grid dedicated to the approach (presences of groups of elements forming of the called particular zones chips) or a sufficiently fine free grid in which the zones are built by the macro-order.

In 3D, only a specific grid dedicated to the approach including of the groups of elements forming of the slices of several chips is usable.

The macro-order turns over a table containing, for each moment of required calculation:

- the name of the zone of calculation (chip) ZONE
- elastic energy in the zone ENER_ELAS
- the length of the zone (or surfaces in 3D) DELTA_L
- the parameter GP
- an indicator specifying the place of the maximum per moment MAX_INST

The user can also ask for a restricted table in which only the lines corresponding to the maximum per moment are given. If the user would have used the automatic construction of the zones of chips, it can ask to obtain at exit a field making it possible to visualize the zones and to check their good definition.

2 Syntax

```
[table] = CALC_GP (  
  ♦ RESULT = resumeca, [result]  
  
  ♦ LIST_INST = moment, [l_R]  
  ♦ PRECISION = /prec, [R]  
  /1E-6 [DEFECT]  
  ♦ CRITERION = /'ABSOLUTE' [DEFECT]  
  /'RELATIVE'  
  
  ♦ GPMAX = CO ('TABGPMAX') [CO]  
  
  #Pour the case 2D:  
  ♦ TRANCHE_2D =_F (  
    ♦ ZONE_MAIL = /'NOT'  
    = /'YES'  
  
  #SI ZONE_MAIL = 'YES':  
    ♦ GROUP_MA = l_group [l_group_ma]  
    ♦ SIZE = l_taille [l_R]  
  
  #SI ZONE_MAIL = 'NOT':  
    ♦ SIZE =  $l_c$  [R]  
    ♦ CENTER = center [R, R, R]  
    ♦ RAY =  $R$  [R]  
    ♦ ANGLE =  $\theta$  [R]  
    ♦ NB_ZONE = N [I]  
    ♦ CHAMP_VISU = CO ('FIELD') [CO]  
  )  
  
  #Pour the case 3D:  
  ♦ TRANCHE_3D =_F (  
    ♦ GROUP_MA = l_group [l_group_ma]  
  )  
  
  #Si TRANCHE_2D:  
  ♦ SYME = /'YES'  
  /'NOT'  
  
  #Si TRANCHE_3D:  
  ♦ FOND_FISS = bottom [bottom]  
  )
```

3 Elastoplastic model of rupture energy Gp

The energy model of prediction of the rupture in elastoplasticity is described more in detail in the reference material [R7.02.16].

The goal of this model is to consider the loading critical of starting of cleavage in an elastoplastic structure; it thus represents a deterministic alternative to the models based on the levels of principal constraint which are Beremin or Bordet (also available in *Code_Aster*).

The model is based on a representation of the defect by a notch; the principle of minimization of the potential energy of the structure compared to the projection of defect only makes it possible final to lead to a criterion on average elastic energy present in particular zones $C(l)$ downstream from the notch and called commonly chips. Figure 3-1 present a definition of these zones, which are thus measured since the bottom of the notch until a distance l ; L_C represent the diameter of the notch here.

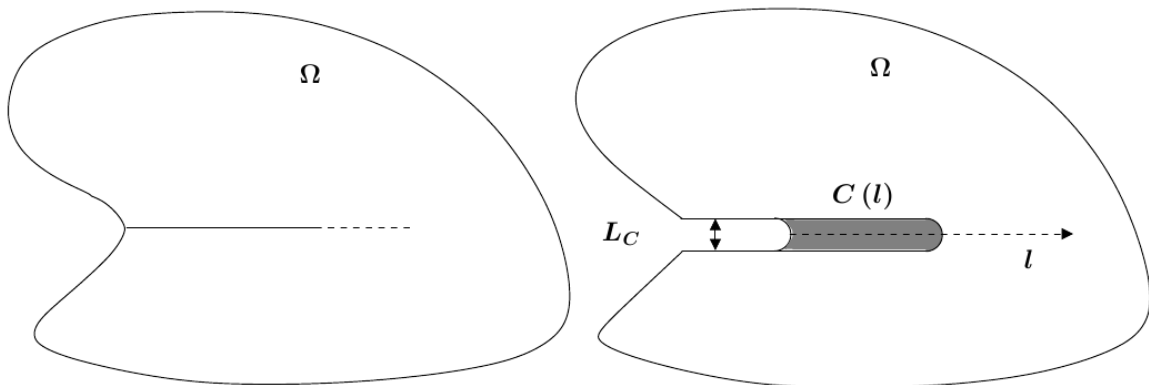

Figure 3-1 - Definition of the zone of interest.

The criterion of cleavage is written then:

$$(\exists l > 0) \tilde{G}_p(l) \geq G_{PC} \text{ with } \tilde{G}_p(l) = \frac{\int_{C(l)} \Phi_{el} d\Omega}{l},$$

where Φ_{el} is elastic energy and G_{PC} is a parameter material to be determined. In 3D, the distance l is replaced by the surface of the chip in the plan of propagation of the notch.

In order to carry out the calculation of elastic energy in these zones called chips, two solutions exist in 2D:

- to have defined these zones in the grid
- to define these zones a posteriori in the free grid

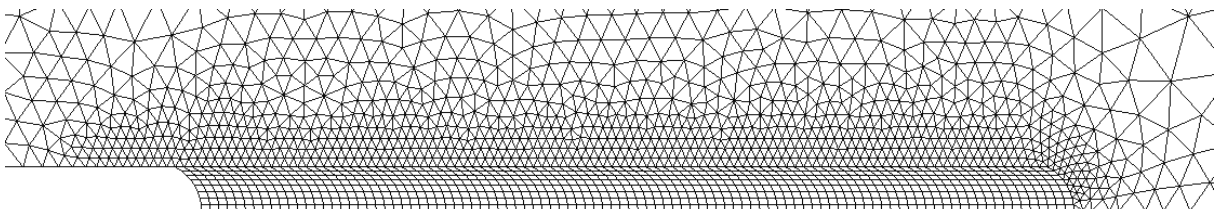

Figure 3-2 - Classical grid with definition of the chips.

In the first case, the Figure 3-2 present a view of the grid to be used. This grid comprises 95 chips of small (with a grid each one by 8 quadrangular finite elements), then a zone of déraffinement. With each chip a group with meshes must then be associated.

In the second case, the Figure 3-3 present a possibility of grid around the notch. This grid must be sufficiently fine in this zone in order to allow a reliable calculation of the parameter of the energy method.

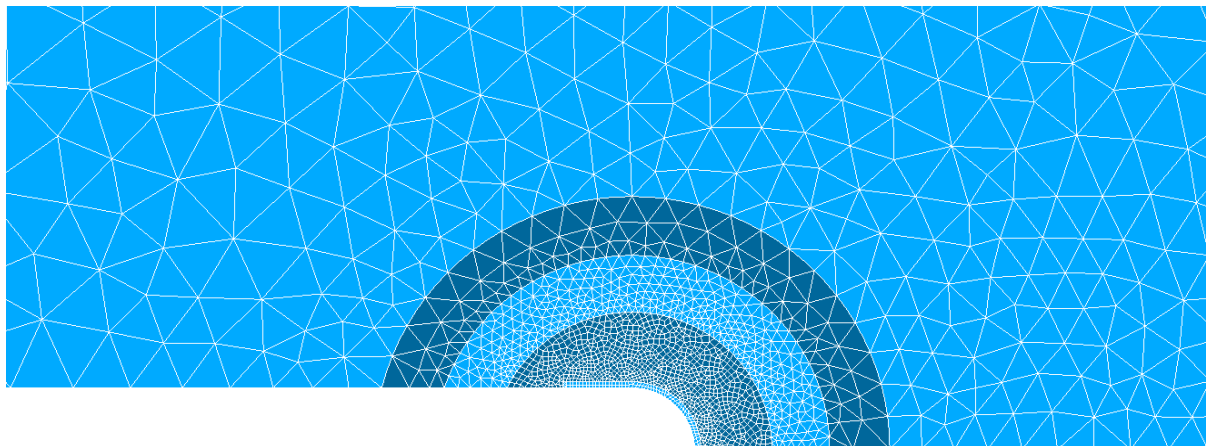

Figure 3-3 - Free grid without definition of the chips.

In 3D, one introduces the concept of slice, each slice containing several chips. The slices follow one another while skirting the face of defect, which is a line. In 2D, there is only one slice, the bottom of defect being brought back to 1 point. One defines the chips of the 1st slice in the same way as in 2D, with the difference which the meshes are voluminal and are obligatorily hexahedral; one continues the list by adding the chips of the 2nd slice in the same way; one obtains with final list $nb_{copeaux} \times nb_{tranches}$ groups of meshes.

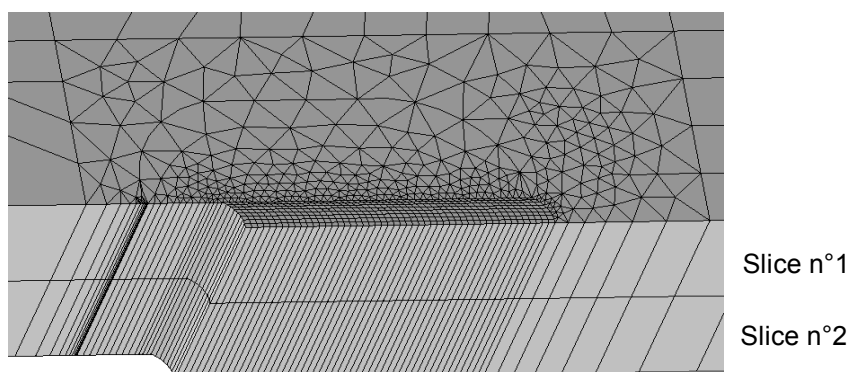

Figure 3-4 Definition of the slices

4 Operands

CALC_GP is an macro-order and thus calls in-house other orders of *Code_Aster*. Most keywords are transmitted such as they are to the other orders. One will indicate thereafter in which (S) order (S) the keywords are used.

4.1 Operand RESULT

◆ RESULT = resumeca, [result]

Indicate the result of the thermomechanical calculation for which one calculates the parameter G_p .
Used by POST_ELEM and CALC_CHAMP.

4.2 Operand LIST_INST

◆ LIST_INST = moment, [l_R]

List of moments to which the parameter will be calculated.

Caution : the sizes from which the parameter G_p is calculated being nonlinear, no temporal extrapolation is not allowed; if one moment is specified, this one must be part of the list of moments of filing of thermomechanical calculation.

Used by POST_ELEM, CREA_CHAMP and CALC_CHAMP.

4.3 Operand PRECISION

◆ PRECISION = /prec, [R]
/1E-6 [DEFECT]

Precision to which the list of moments must be considered.

4.4 Operand CRITERION

◆ CRITERION = /'ABSOLUTE' [DEFECT]
/'RELATIVE'

Indicate LE standard of precision for the determination of the list of moments.

4.5 Operand GP_MAX

◆ GPMAX = CO ('TABGPMAX') [CO]

Indicate if the user wishes to obtain as a result one second table, restriction of the obligatory complete table containing only the line of the place of the maximum of the parameter G_p for each moment of calculation.

4.6 Operand TRANCHE_2D

◆ TRANCHE_2D = _F (

```
♦ ZONE_MAIL      = / 'NOT'  
                 = / 'YES'  
  
#SI ZONE_MAIL = 'YES':  
  ♦ GROUP_MA     = l_group           [l_group_ma]  
  ♦ SIZE         = l_taille          [l_R]  
  
#SI ZONE_MAIL = 'NOT':  
  ♦ SIZE         = size [R]  
  ♦ CENTER       = center            [R, R, R]  
  ♦ RAY          = R                  [R]  
  ♦ ANGLE        = θ                  [R]  
  ♦ NB_ZONE      = N                  [I]  
  ♦ CHAMP_VISU   = CO ('FIELD')      [CO]
```

Indicate the whole of the geometrical parameters necessary to calculation energy parameter.

4.6.1 Keyword ZONE_MAIL

```
♦ ZONE_MAIL      = / 'NOT'  
                 = / 'YES'
```

Indicate if the grid represents the geometry of the zones of chips.
So 'YES', one is in the case of a grid such as on the Figure 3-2.

4.6.2 Case ZONE_MAIL = 'YES'

4.6.2.1 Keyword GROUP_MA

```
♦ GROUP_MA      = l_group           [l_group_ma]
```

List of the groups of meshes on which calculations will be carried out.
Each group of meshes must correspond to a zone of chips.

Used by POST_ELEM.

4.6.2.2 Keyword SIZE

```
♦ SIZE          = l_taille [l_R]
```

List of sizes of the zones. This list must be same size as the list of the groups of mesh.

4.6.3 Case ZONE_MAIL = 'NOT'

In this case, a geometrical zone of calculation is built by the macro one. The following parameters make it possible to define it. The Figure 4-1 present the parameters of definition of these zones; it represents a notch of center C_{ent} , of ray R ; the third zone $C_3(l)$ of length $3 \times l_C$ is hatched.

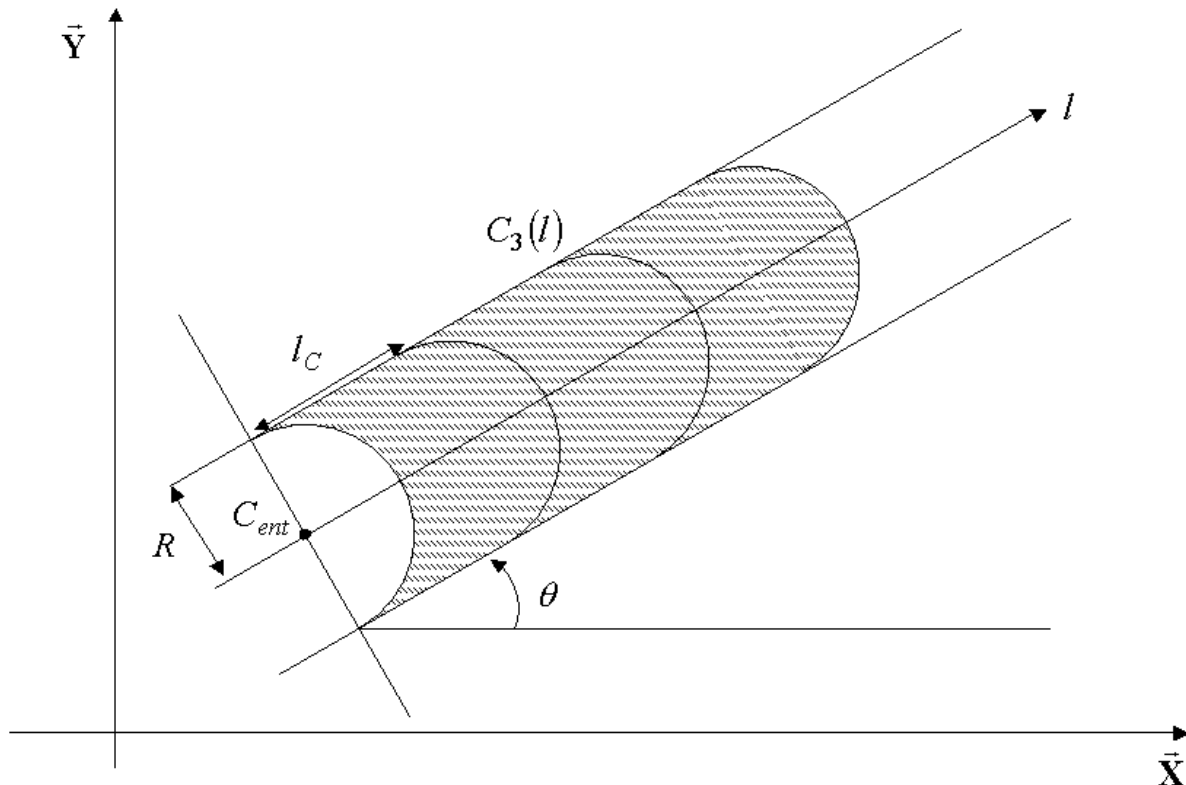

Figure 4-1 - Geometrical definition of the zones in the case nonwith a grid.

4.6.3.1 Keyword SIZE

◆ SIZE = l_C [R]

Increment of the size of the zones. The zone N is thus of size $n * l_C$.

Used by FORMULA.

4.6.3.2 Keyword CENTER

◆ CENTER = center [R, R, R]

Indicate the coordinates of the center of the notch C_{ent} in the total reference mark.

Used by FORMULA.

4.6.3.3 Keyword RAY

◆ RAY = R [R]

Indicate the ray of the notch.

Used by FORMULA.

4.6.3.4 Keyword ANGLE

◆ ANGLE = θ [R]

Indicate the angle formed between the direction of the notch and the axis \vec{X} total reference mark. The angle must be given in degrees and measured in the trigonometrical direction.

Used by FORMULA

4.6.3.5 Keyword NB_ZONE

◆ NB_ZONE = N [I]

Indicate the number of zones (chips) considered in calculation.

4.6.3.6 Keyword CHAMP_VISU

◇ CHAMP_VISU = CO ('FIELD') [CO]

If the user wishes it, it can ask for the exit of a field the points of Gauss representing the chips. The value of this field is 1 in the zone of chip and 0 elsewhere. The Figure 4-2 present a visualization of this field for the grid presented of Figure 3-3.

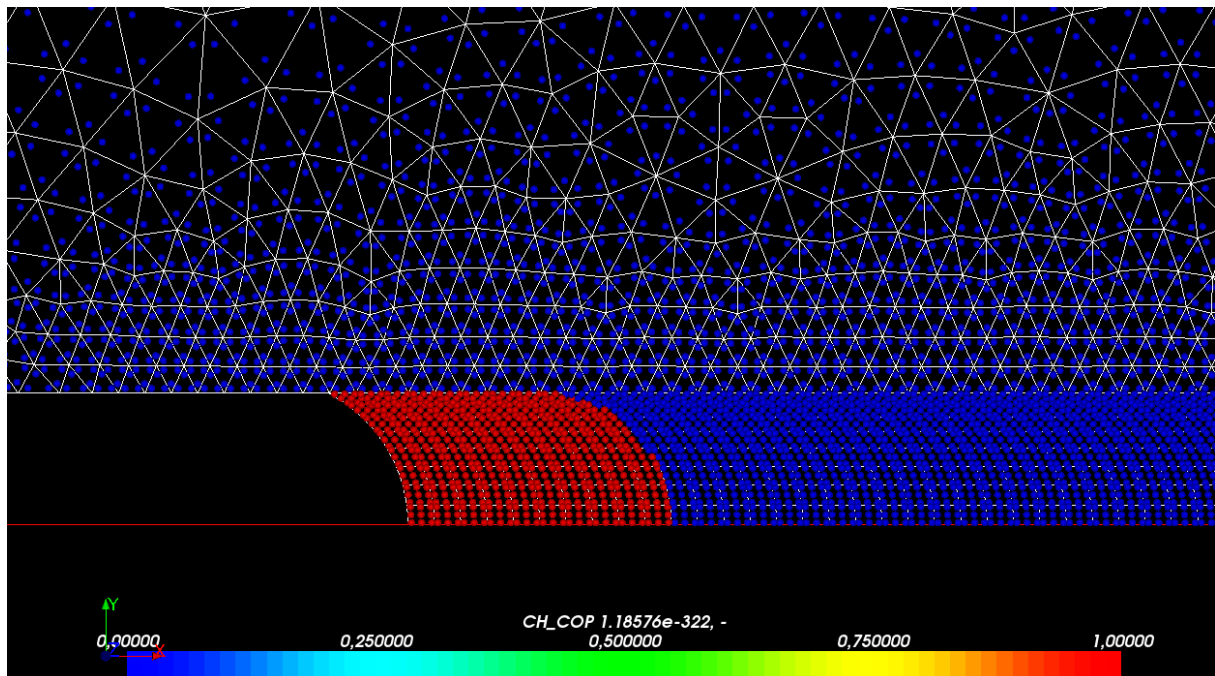

Figure 4-2 - Field of visualization of the chips.

4.7 Operand TRANCHE_3D

◇ TRANCHE_3D = _F (
 ◆ GROUP_MA = l_group [l_group_ma]
))

4.7.1 Keyword GROUP_MA

◆ GROUP_MA = l_group [l_group_ma]

List of the groups of meshes on which calculations will be carried out.

Each group of meshes must correspond to a zone of chips.

Each list of group of meshes corresponds to a given slice; the groups of meshes to the interior of each list must correspond to the chips and be ordered nearer to the bottom of defect to most distant.

Used by POST_ELEM.

4.8 Operand SYME

```
#Dans the case 2D
♦ SYME = / 'YES'
        / 'NOT'
```

Inform if a symmetry of the structure compared to the notch made it possible to carry out a grid only half of the structure. On the figures 3-2 and 3-3, only the part of the structure higher than the notch is defined; in this case, the user will inform SYME=' OUI ' and the result indicated in the table will take account of symmetry (multiplied by two).

4.9 Operand FOND_FISS

```
#Si TRANCHE_3D:
♦ FOND_FISS = bottom [bottom]
```

In 3D, the user must define a bottom of crack beforehand, with separated lip (since the defect is represented by a notch).

This bottom of crack allows in particular the calculation of the areas (denominator of the calculation of G_p).

5 Examples of use

One will find examples in the cases test SSNV218a, SSNP131a and SSNP131b.