Note of use of the elements discrete

Summary:

This document is a note of use for modelings of the discrete elements.

The discrete elements play a part in digital modeling of stiffnesses, depreciation or masses located on a node or between two nodes.

They are usable in linear or non-linear mechanics.

Contents

1 Introduction.....	3
2 Assignment of the properties of the discrete ones.....	4
2.1 Meshs supports of the discrete ones.....	4
2.2 Space discretization and assignment of a modeling.....	4
2.3 Degrees of freedom.....	4
2.3.1 Meshs support of the matrices.....	4
2.3.2 Model: AFFE_MODELE.....	4
2.3.3 Elementary characteristics, operator AFFE_CARA_ELEM.....	5
2.3.4 Materials: DEF1_MATERIAU.....	6
2.3.5 Limiting loadings and conditions: AFFE_CHAR_MECA and AFFE_CHAR_MECA_F.....	8
3 Resolution.....	10
3.1.1 Linear calculations: MECA_STATIQUE and other linear operators.....	10
3.1.2 Nonlinear calculations: STAT_NON_LINE and DYNA_NON_LINE.....	10
3.1.3 Explicit nonlinear calculations on modal basis: DYNA_VIBRA (TRAN/GENE) / DYNA_TRAN_MODAL.....	10
4 Additional calculations and postprocessings.....	11
4.1.1 Calculations by elements: operators CALC_CHAMP.....	11
4.1.2 Calculations of quantities on whole or part of the structure: operator POST_ELEM.....	11
4.1.3 Calculations of separation: operator POST_DECOLLEMENT.....	11
5 Remarks.....	12
5.1.1 Longuor of the discrete elements.....	12
5.1.2 Transmission of the efforts.....	12
6 Examples.....	13
6.1.1 Elements of mass.....	13
6.1.2 Elements of stiffness.....	14
6.1.3 Elements of damping.....	18
6.1.4 Other uses.....	19
7 Bibliography.....	22

1 Introduction

The discrete elements are used to model very simply masses, springs or of the shock absorbers. They are used to assign specific properties to nodes of the grid and to define specific masses, stiffnesses and damping of supports.

These modelings are usable in linear and nonlinear mechanics, under the assumption of small displacements.

Three categories of elements the discrete ones are described in this document:

- mass,
- stiffness,
- shock absorber,

In a first part, one presents the setting in data of the properties of the discrete elements with the various options available.

One gives in the second and third part the operators of calculation and postprocessing for the discrete elements.

The last part gives a list of case tests, examples of use of the discrete ones.

2 Assignment of the properties of the discrete ones

2.1 Meshes supports of the discrete ones

The meshes supports of the discrete elements are `POI1` (mesh with a node) or `SEG2` (segment with two nodes).

2.2 Space discretization and assignment of a modeling

In this part, one describes the choice and the assignment of one of discrete modelings as well as the degrees of freedom and the associated meshes. Most described information are extracted from documentations of use of modelings:

- [U3.11.02] : Modelings `DIS_T` and `DIS_TR`.
- [U3.13.09] : Modeling `2D_DIS_T` and `2D_DIS_TR`.

2.3 Degrees of freedom

The degrees of freedom of discretization are defined in each node of the mesh support. Components, depending on modeling chosen, are given in the following table.

Modeling	Degrees of freedom (with each node)				
<code>2D_DIS_T</code>	<code>DX</code>	<code>DY</code>			
<code>2D_DIS_TR</code>	<code>DX</code>	<code>DY</code>			<code>DRZ</code>
<code>DIS_T</code>	<code>DX</code>	<code>DY</code>	<code>DZ</code>		
					<code>DRY</code>
<code>DIS_TR</code>	<code>DX</code>	<code>DY</code>	<code>DZ</code>	<code>DRX</code>	<code>MARTI DRZ</code>
					<code>NI</code>

2.3.1 Meshes support of the matrices

Modeling	Mesh	Finite element
<code>2D_DIS_T</code>	<code>POI1</code>	<code>MECA_2D_DIS_T_N</code>
	<code>SEG2</code>	<code>MECA_2D_DIS_T_L</code>
<code>2D_DIS_TR</code>	<code>POI1</code>	<code>MECA_2D_DIS_TR_N</code>
	<code>SEG2</code>	<code>MECA_2D_DIS_TR_L</code>
<code>DIS_T</code>	<code>POI1</code>	<code>MECA_DIS_T_N</code>
	<code>SEG2</code>	<code>MECA_DIS_T_L</code>
<code>DIS_TR</code>	<code>POI1</code>	<code>MECA_DIS_TR_N</code>
	<code>SEG2</code>	<code>MECA_DIS_TR_L</code>

Notice :

In a mesh, to transform a node into a mesh `POI1`, one can use order `CREA_MALLAGE` with keyword `CREA_POI1` (see [U4.23.02]).

2.3.2 Model: `AFFE_MODELE`

The assignment of modeling passes through the operator `AFFE_MODELE` [U4.41.01].

<code>AFFE_MODELE</code>	
<code>AFFE</code>	
<code>PHENOMENON :</code>	<code>'MECHANICAL'</code>
<code>MODELING</code>	<code>'2D_DIS_T'</code>
	<code>'2D_DIS_TR'</code>
	<code>'DIS_T'</code>
	<code>'DIS_TR'</code>

2.3.3 Elementary characteristics, operator AFFE_CARA_ELEM

In this part, the operands characteristic of the discrete elements are described. The documentation of use of the operator AFFE_CARA_ELEM is [U4.42.01].

These keywords make it possible to assign directly to entities (meshes or nodes), which support elements of the type DIS_T, DIS_TR (DISCRETE) or 2D_DIS_T, 2D_DIS_TR (DISCRET_2D), **matrices of rigidity, of mass or of damping.**

The characteristics can be defined by one of the four following keywords and govern the linear elastic behavior.

2.3.3.1 Key word: DISCRETE or DISCRET_2D

The characteristics of discrete are described by the following nomenclature:

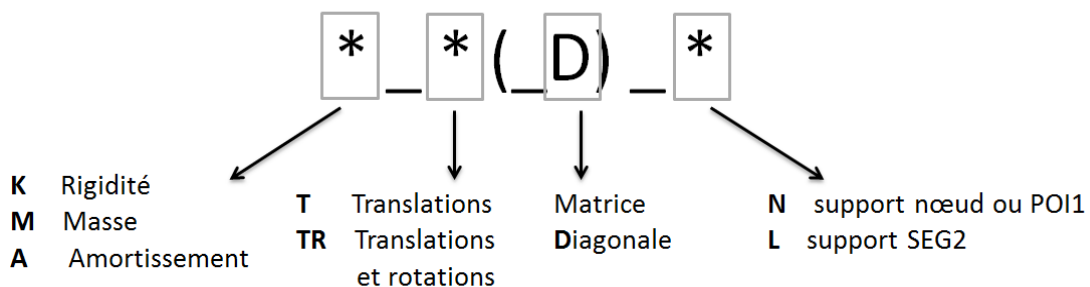

The possibilities of assignment of the matrices are:

- Matrices of rigidity
K_T_D_N, K_TR_D_N, K_T_D_L, K_TR_D_L, K_T_N, K_TR_N, K_T_L, K_TR_L
- Matrices of mass
M_T_D_N, M_TR_D_N, M_T_D_L, M_TR_D_L, M_T_N, M_TR_N, M_T_L, M_TR_L
- Matrices of damping
A_T_D_N, A_TR_D_N, A_T_D_L, A_TR_D_L, A_T_N, A_TR_N, A_T_L, A_TR_L

The number of values necessary to define the matrices is function of the characteristic chosen in [U4.42.01].

By defaults, the characteristics are given in the total reference mark. The local reference mark can be defined for a node, a mesh POI1 or nets SEG2 thanks to the keyword ORIENTATION of AFFE_CARA_ELEM and while specifying REPERE=' LOCAL'.

Note:

- The index *T* or *TR* must be compatible with the definition of the models in AFFE_MODELE: DIS_T or DIS_TR
- One can apply characteristics of masses and rigidity to the same mesh. If one affects only one mass on discrete, one obtains alarm DISCRETS_27 to indicate that a worthless stiffness is considered. Alarm DISCRETS_26 is emitted if one affects only one stiffness. To remove these alarms the various matrices should be informed.
- The keyword AMOR_HYST=*amor_h* allows to build a complex matrix of rigidity (hysteretic modeling of damping); the built matrix is: $(1 + j.amor_h).K$ where *K* is the matrix *K_** whose values are provided in the same occurrence of the keyword DISCRETE. The matrix of rigidity complexes will be built at the time of a call to CALC_MATR_ELEM [U4.61.01] with the option AMOR_HYST (see test SDLD313 and [R5.05.04]).
- The complete definition of the matrices of rigidity, mass or damping makes it possible to define offset elements. The case test SDNL113 set the example of unbalance (V5.02.113).

2.3.3.2 Key word: RIGI_PARASOL

This functionality corresponds to a methodology used to determine the characteristics discrete

elements (springs of translation and/or rotation) to apply to the nodes of a foundation raft from total stiffnesses.

This option is available in 3D and in 2D . In the case 3D the foundation raft will be modelled by a surface, in the case 2D it will be modelled by a line (test SSNL130 [V6.02.130]). In the case 2D, the discrete ones are 2D_DIS_TR or 2D_DIS_T.

The key word factor RIGI_PARASOL distributes 6 stiffnesses total proportionally on surfaces of the elements surrounding its nodes.

Case tests: SSSL118C and D [V2.03.118] and SSNL130 With and B [V6.02.130]

2.3.3.3 Key word: RIGI_MISS_3D

This keyword will affect the exact terms of a matrix of impedance calculated by MISS3D for all degrees of freedom of interface (3 times the number of nodes) and for a frequency of extraction given. The assignment of these terms (modeling DIS_T) is done then with the specific meshes POI1 nodes of the surface foundation.

Case test: SDNX101A [V5.05.101].

2.3.3.4 Key word: MASS_AJOU

In this new option MASS_AJOU , one distributes with the nodes of the interface fluid-structure via characteristics M_T_N of the elementary values of directional mass obtained by integration of the normal pressure to each element (starting from functions of distribution of this normal pressure depending on the coordinates, in particular of altitude) in order to express relations of Westergaard for example or more simply the expression of the hydrostatic pressure.

The assignment of these terms (modeling DIS_T to declare in AFFE_MODELE) is done then with the specific meshes POI1 nodes of the interface fluid-structure using the keyword GROUP_MA_POI1 keyword factor MASS_AJOU.

Case test: FDLV112C [V8.01.112].

2.3.3.5 Key word: MASS_REP

The objective is to take into account simply a mass and to distribute it on a surface. The option MASS_REP, allows to distribute with the nodes of discrete of characteristic 'M_T_D_N' values of mass obtained in proportion to the surface of the surface meshes or length of the linear meshes.

The assignment (modeling 'DIS_T' to declare in AFFE_MODELE) is done on specific meshes of type POI1.

Case test: ZZZ384A [V1.01.384].

2.3.4 Materials: DEFI_MATERIAU

The definition of the parameters describing the behavior non_linéaire of a material is carried out using the operator DEFI_MATERIAU [U4.43.01] and the choice of the behavior in the keyword BEHAVIOR of STAT_NON_LINE or DYNA_NON_LINE.

The detail of the laws of behaviors of discrete is given in documentation [R5.03.17] Relations of behavior of the discrete elements, except for the law WEAPON and the law ASSE_CORN [R5.03.32].

- WEAPON

The law of behavior WEAPON allows to model the behavior of an armament of airline. It is about one law of trilinear behavior non-linear (with discharge) being able to represent the rupture of an armament of airline.

Case test: SSNL101 [V6.02.101].

- ASSE_CORN [R5.03.32]

The law of behavior ASSE_CORN allows to model the non-linear behavior of angles of pylons (DIS_TR). The law represents at the same time behaviour in traction of the assembly and the relation moment-rotation around the axis of the bolts, perpendicular to the assembly. The other directions of loading present a linear elastic behavior described by classical characteristics of rigidity.

Case test: SSNL102A [V6.02.102].

- DIS_BILI_ELAS [R5.03.17]
The law of behavior DIS_BILI_ELAS allows to model a bilinear elastic behavior in translation, in each direction. The coefficients of the bilinear law can depend on the temperature.
Case test: SSND103A/B/C [V6.08.103].
- DIS_CHOC [R5.03.17]
The law of behavior DIS_CHOC allows to model the contact with shock and friction between two structures, via two types of relations:
 - the relation of unilateral contact which expresses to it not inter-penetrability between the solid bodies,
 - the relation of friction of Coulomb which governs the variation of the tangential stresses in the contact.Case tests:
 - SDLS119A/B [V2.03.119] Taking into account of separation
 - SSND116A Contact with friction (static study)
 - SDND100C [V5.01.100] Contact with friction (dynamic study)
 - SDND102B/C [V5.01.102] Shock between masses in dynamics
 - SSNL130A/B [V6.02.130] Static study with RIGI_PARASOL
- DIS_ECRO_CINE [R5.03.17]
The law of behavior DIS_ECRO_CINE is Uelastoplastic law of behaviour to nonlinear kinematic work hardening.
Case tests: SSND102A/B [V6.08.102] (static study)
- DIS_GOUJ2E_ELAS or_PLAS [R5.03.17]
These laws of behavior make it possible to model a relation of behavior of the elastoplastic type to isotropic work hardening, binding the efforts in the discrete element unlike displacement of the two nodes in the direction y local. The equations are deduced from the behavior 3D VMIS_ISOT_TRAC [R5.03.02].
Case tests: ZZZZ120 [V1.01.120]
- DIS_GRICRA [R5.03.17]
The behavior DIS_GRICRA allows to model behaviour in translation and rotation within the competences of connection grid-pencil of the fuel assemblies. This behavior is available for meshes SEG2.
Case tests: SSNL131 [V6.02.131]
- DIS_VISC [R5.03.17]
The law of behavior DIS_VISC allows to model a nonlinear viscoelastic rheological behavior, of type Zener extended, allowing to schematize the behavior of an axial plain shock absorber.
Case tests: SSND101A/B/C/D [V6.08.103] (static study) and SDND107A/B/C/D/E [V5.01.107] (dynamic study).

These relations directly bind the efforts and displacements, instead of being formulated between constraints and deformations. They are valid only in small displacements.

The laws of behaviors are available for the non-linear operators STAT_NON_LINE and DYNA_NON_LINE.

Certain modelings can also be taken into account for linear transitory analyses via the operator DYNA_VIBRA : DIS_VISC, SHOCK,...

Behavior in STAT_NON_LINE DYNA_NON_LINE	Type of element (modeling) in AFFE_MODELE	Keywords in DEFI_MATERIAU	With FFE_CARA_ELEM keywords under DISCRETE
WEAPON	DIS_T, DIS_TR	WEAPON	CARA: 'K_T_D_L' CARA: 'K_TR_D_L' CARA: 'K_T_D_N' CARA: 'K_TR_D_N'
ASSE_CORN	DIS_T, DIS_TR	ASSE_CORN	CARA: 'K_T_D_L' CARA: 'K_TR_D_L' CARA: 'K_T_D_N' CARA: 'K_TR_D_N'
DIS_BILI_ELAS	DIS_T, 2D_DIS_T, DIS_TR, 2D_DIS_TR discrete elements 2D or 3D with one or two nodes in translation/rotation	DIS_BILI_ELAS	CARA: 'K_T_D_L' CARA: 'K_TR_D_L' CARA: 'K_T_D_N' CARA: 'K_TR_D_N'
DIS_CHOC contact and shock with friction of Coulomb	DIS_T, 2D_DIS_T discrete elements 2D or 3D with two nodes in translation.	DIS_CONTACT	CARA: 'K_T_D_L' CARA: 'K_T_D_N' For the calculation of rigidity elastic and clean modes
DIS_ECRO_CINE	DIS_T, D_DIS_T, DIS_TR, 2D_DIS_TR discrete elements 2D or 3D with one or two nodes in translation/rotation	DIS_ECRO_CINE	CARA: 'K_T_D_L' CARA: 'K_TR_D_L' CARA: 'K_T_D_N' CARA: 'K_TR_D_N'
DIS_GOUJ2E_ELAS DIS_GOUJ2E_PLAS	2D_DIS_T discrete element 2D with two nodes in translation	TRACTION	CARA: 'K_T_D_L'
DIS_GRICRA	DIS_TR discrete elements 3D with two nodes in translation/rotation	DIS_GRICRA	CARA: 'K_TR_L' For the calculation of rigidity elastic and clean modes
DIS_VISC	DIS_T, 2D_DIS_T, DIS_TR, 2D_DIS_TR discrete elements 2D or 3D with one or two nodes in translation/rotation	DIS_VISC	CARA: 'K_T_D_L' CARA: 'K_TR_D_L' CARA: 'K_T_D_N' CARA: 'K_TR_D_N'

2.3.5 Limiting loadings and conditions: AFFE_CHAR_MECA and AFFE_CHAR_MECA_F

The documentation of use of AFFE_CHAR_MECA and AFFE_CHAR_MECA_F is [U4.44.01] .

The supported loadings are the following:

- **GRAVITY**

This loading makes it possible to apply a loading of type gravity.

Supported modelings: 2D_DIS_T, 2D_DIS_TR, DIS_T, DIS_TR

Case tests: SDLD04A [V2.01.004]

- **LIAISON_ELEM**

The discrete elements can be used within the framework of connection between pieces of structure of different modelings.

The possible options are 3D_POU, 2D_POU, COQ_POU and PLAQ_POUT_ORTH. The option 3D_POU allows to connect a massive part with a node to 6 degrees of freedom. Case test SDLV122A/B [V2.04, 122].

- The option 2D_POU the meshes of a surface part 2D with a discrete element makes it possible to connect. Case test SSLX100F/G [V3.05.100].

- The option `COQ_POU` allows to connect a part with a grid in hull with a node of a discrete element. Case test `SDLL135F [V2.02.135]`.
- The option `PLAQ_POUT_ORTH` allows to connect a part with a grid with elements `TRIA3` and `QUA4` with a part modelled by a discrete element.
- **DDL_IMPO/LIAISON_DDL/LIAISON_UNIF /LIAISON_SOLIDE**
Boundary conditions on the nodes of the discrete elements with 2 nodes (mesh `SEG2`) can be defined with these operators.

3 Resolution

3.1.1 Linear calculations: MECA_STATIQUE and other linear operators

Linear calculations are carried out in small deformations. Several linear operators of resolution are available for the following studies:

- **Static analysis: operators MECA_STATIQUE/MACRO_ELAS_MULT**
Resolution of a problem of static mechanics linear.
Case tests: SDDL105A [V2.01.105]
- **Modal analysis: operators MODE_ITER_SIMULT/MODE_ITER_INV**
Calculation of the values and clean vectors.
Case tests: SDDL27A/E [V2.01.027]
- **Dynamic analysis: operators DYNA_VIBRA / TRAN/PHYS**
Calculation of the transitory dynamic response to an unspecified temporal excitation.
Case tests: SDDL106A [V2.01.106]
- **Dynamic analysis: operators DYNA_VIBRA / HARM/PHYS**
Calculation of the transitory dynamic response to a harmonic excitation.
Case tests: SDDL106A [V2.01.106]
- **Dynamic analysis: operators DYNA_VIBRA / TRAN/GENE**
Calculation of the transitory dynamic response to a temporal excitation on modal basis
Case tests: SDDL22A [V2.01.022]
- **Dynamic analysis: operators DYNA_VIBRA / HARM/GENE**
Calculation of the transitory dynamic response to a harmonic excitation on modal basis.
Case tests: SDDL21B [V2.01.021]

3.1.2 Nonlinear calculations: STAT_NON_LINE and DYNA_NON_LINE

For the non-linear laws of behavior, cf §2.1.4, the non-linear operators must be used:

- **Static analysis: operators STAT_NON_LINE**
Calculation of the non-linear static answer
Case tests: SSNV503 [V6.04.503]
- **Dynamic analysis: operators DYNA_NON_LINE**
Calculation of the non-linear dynamic response
Case tests: SSNV104 [V5.03.104]

3.1.3 Explicit nonlinear calculations on modal basis: DYNA_VIBRA (TRAN/GENE) / DYNA_TRAN_MODAL

Certain non-linear behaviors for discrete elements can be used in the dynamic operator `DYNA_VIBRA`. In this case, the modeling of the discrete elements is not obligatory and the law of behavior can be directly defined between two nodes or groups of nodes:

- Modeling of one `SHOCK` : study of structures whose displacements are limited in one or more points by the presence of an obstacle.
Case test: SDND104A [V5.01.104]
- Modeling of a non-linear viscous shock absorber of type 'Zener'.
Case test: SDND107C [V5.01.107]
- Modeling of a non-linearity of type effort-displacement.
Case test: SDND103A [V5.01.103]

4 Additional calculations and postprocessings

4.1.1 Calculations by elements: operators `CALC_CHAMP`

Options of postprocessing available via `CALC_CHAMP` are:

- `SIEF_ELGA`
- `SIEF_ELNO`
- `EFGE_ELGA`
- `EFGE_ELNO`

All these fields give the calculation of the efforts generalized by element to the points of gauss or the nodes starting from displacements in the local reference mark of the element.

For the discrete ones of type 'POI1', the point of Gauss is with the same position as the node. For discrete of type 'SEG2', the point of Gauss is in the middle of the segment (Case test `ZZZZ266A`).

There are no options of postprocessing of the deformations, because the laws of behavior are expressed in force-displacement and not in stress-strains.

4.1.2 Calculations of quantities on whole or part of the structure: operator `POST_ELEM`

The operator `POST_ELEM` (documentation [U4.81.22]) allows to calculate quantities on whole or part of the structure. The calculated quantities correspond to particular options of calculation of affected modeling.

The options available for the discrete elements are:

- `MASS_INER` : calculation of the geometrical characteristics (volume, centre of gravity, matrix of inertia).
- `ENER_POT` : calculation of the potential energy of deformation due to balance starting from displacements in linear mechanics of the continuous mediums (2D and 3D) and in linear mechanics for the elements of structures.
- `ENER_CIN` : calculation of the kinetic energy starting from a field speed or a field of displacement and of a frequency (only for the elements of structure and the elements 3D).

Options `ENER_ELAS` and `ENER_TOTALE` are not yet available for the discrete elements.

4.1.3 Calculations of separation: operator `POST_DECOLLEMENT`

This operator of postprocessing calculates the surface of contact or taken off between the foundation raft and the ground during a calculation of interaction ground/structure (ISS), carried out with the operator `DYNA_NON_LINE`.

This postprocessing can be useful for example for a modeling of the ground with elements whose characteristics are indicated with the assistance `RIGI_PARASOL` and affected of the law of behavior `DIS_CHOC` (see case test `ZZZZ200D [V1.01.200]`).

5 Remarks

5.1.1 Longuor of the discrete elements

For the discrete elements whose mesh support is an element with two nodes `SEG2`, the length of the element does not intervene in the answer of the element, except for the law of behavior `DIS_CHOC`. Indeed for the other laws of behavior, the relation is expressed according to relative displacements of the two nodes.

For the law `DIS_CHOC`, the length of the element intervenes in the determination of the state of contact or separation by comparing the displacement of the nodes according to the length of the element and values `DIST_1` and `DIST_2`.

5.1.2 Transmission of the efforts

There is no transmission of the moment related to a couple. This limitation is illustrated if a displacement is imposed `DY` between two nodes of a discrete element `DIS_TR` or `DIS_T`.

Two forces `FY` nodal reactions are equal and opposite but this couple does not generate moments for the case `DIS_T` and for the case `DIS_TR` if the terms of couplings (translation-rotation) are supposed to be worthless.

For discrete elements big length, one will be able to thus find an assessment total of the moments not wished.

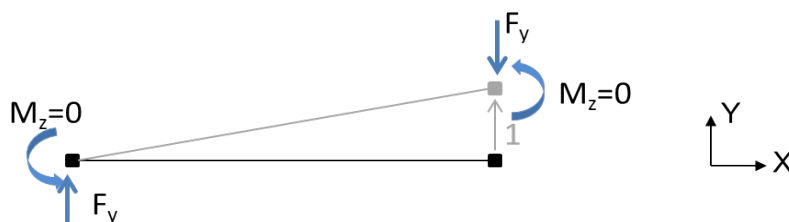

6 Examples

The cas-tests selected illustrate the various possible uses of the discrete elements.

6.1.1 Elements of mass

Modeling of a specific mass $M_T_D_N$

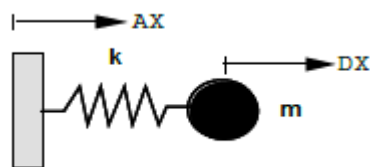

SDLD34

Title: To release of simple mass-arises

Documentation V: [V2.01.034]

Modelings:

SDLD34A DIS_T/M_T_D_N

SDLD34B DIS_T/M_T_D_N

Modeling of a specific mass $M_TR_D_N$ in rotation

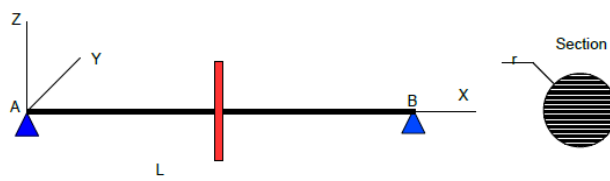

SDLL123

Title: Frequency of a line of trees simplified with gyroscopy

Documentation V: [V2.02.123]

Modelings:

SDLL123A DIS_TR/M_TR_D_N

SDLL123B DIS_TR/M_TR_D_N

SDLL123C DIS_TR/M_TR_D_N

SDLL123D DIS_TR/M_TR_D_N

SDLL123E DIS_TR/M_TR_D_N

SDLL123F DIS_TR/M_TR_D_N

Modeling of unbalance

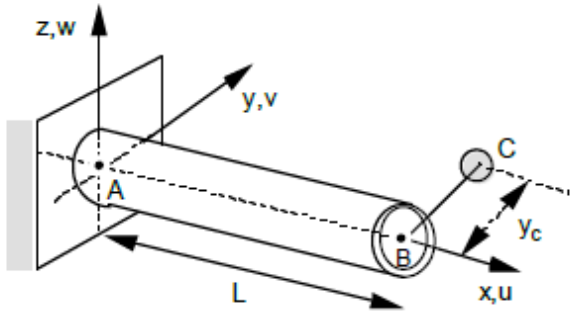

SDLL15

Title: Hurlled, embed-free beam with mass or offset inertia

Documentation V: [V2.02.015]

Modelings:
SDLL15A DIS_TR/M_TR_D_N

6.1.2 Elements of stiffness

Modeling of stiffnesses to the supports

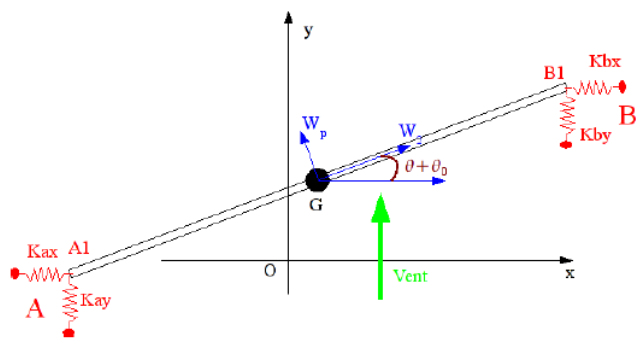

SDNL102

Title: Beam subjected to a field speed of wind

Documentation V: [V5.02.102]

Modelings:
SDNL102A DIS_T /K_T_D_L

Modeling of matrices of nonsymmetrical stiffness and damping

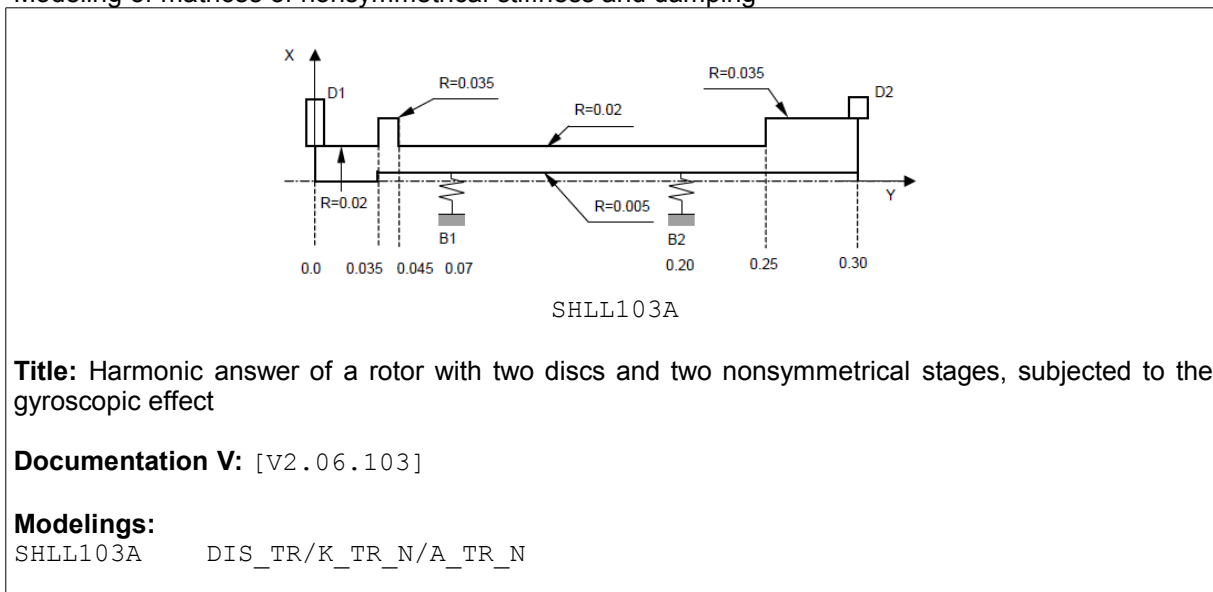

Modeling of simple structural elements

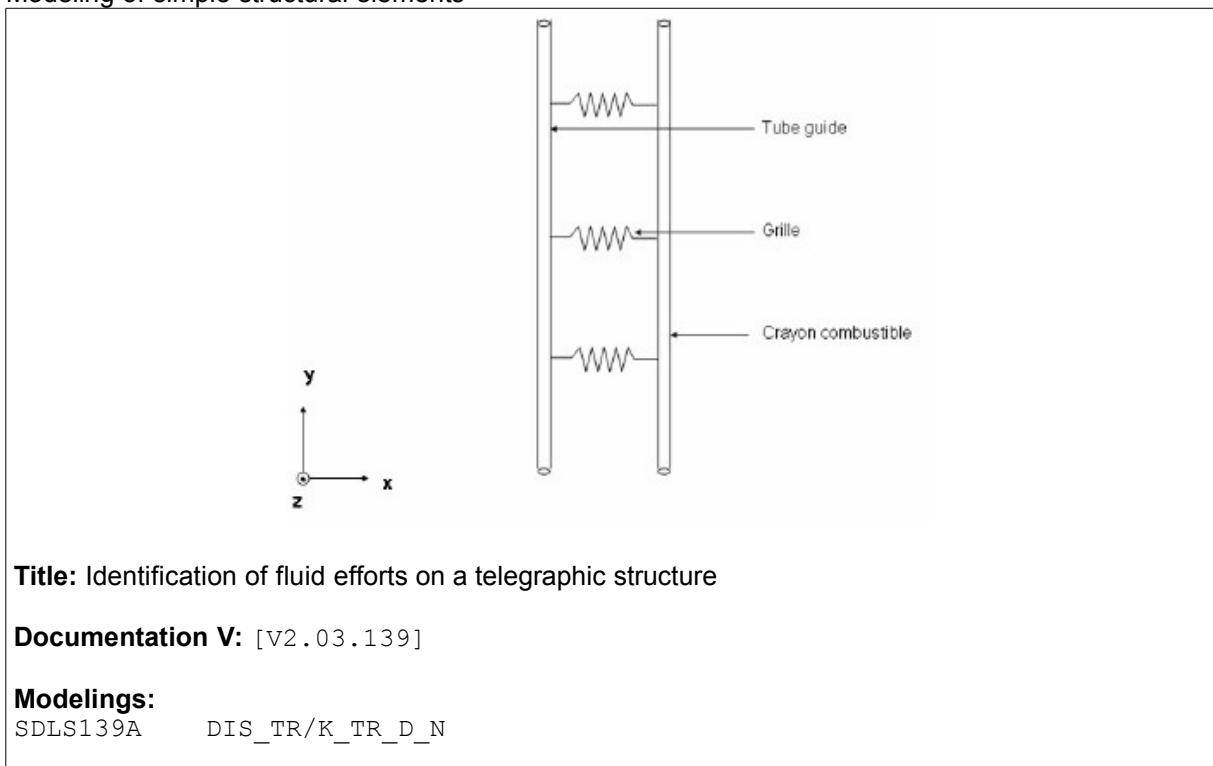

Modeling of the stiffnesses of the ground distributed

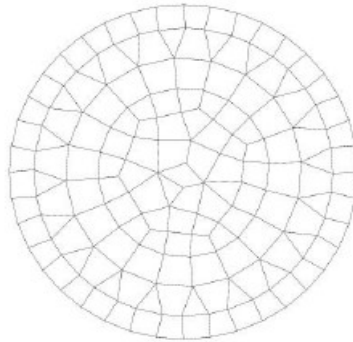

SDLS118C

Title: Response of a rigid circular foundation to a variable seismic excitation in space

Documentation V: [V2.03.118]

Modelings:

SDLS118C DIS_TR/K_TR_D_N
SDLS118D DIS_TR/K_TR_D_N

Modeling of stiffnesses of ground distributed with separation

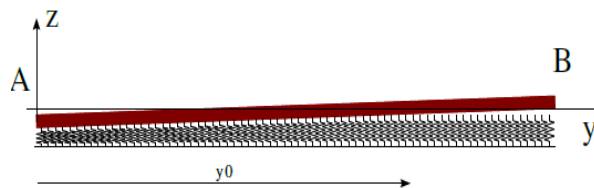

SSNL130

Title: Indeformable plate on a carpet of springs

Documentation V: [V6.02.130]

Modelings:

SSNL130A DIS_T/K_T_D_L
SSNL130B 2D_DIS_T/K_T_D_L

Note: Use of the law DIS_CHOC

Modeling of a bolted assembly

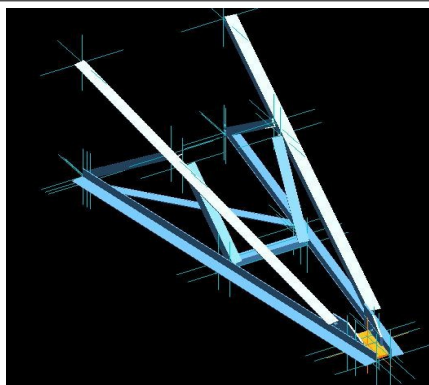

SSNL135

Title: Determination of the loads of ruin of console MEKELEC

Documentation V: [V3.03.020]

Modelings:

SSNL135A	DIS_TR
SSNL135B	DIS_TR
SSNL135C	DIS_TR

Note: Each bolt is represented by a discrete element worthless length and its stiffness $K_{TR_D_L}$.

Modeling of a crack of a rotor

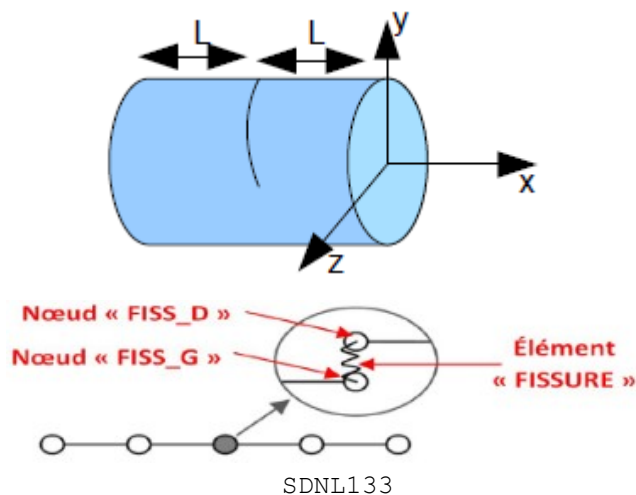

Title: Turning fissured rotor, subjected to a bending stress

Documentation V: [V5.02.133]

Modelings:

SDNL133A	DIS_TR
SDNL133A	DIS_TR
SDNL133A	DIS_TR

See documentation Note of implementation of calculations of rotors [U2.06.32].

6.1.3 Elements of damping

Documentations of modeling of the mechanical cushioning are:

- [R5.05.04] Modeling of damping in linear dynamics
- [U2.06.03] Note of modeling of the mechanical cushioning

Modeling of viscous damping

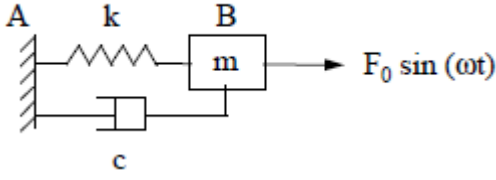

SDLD321

Title: Transitory dynamic response of one harmonic oscillator with damping variable

Documentation V: [V2.01.321]

Modelings:

SDLD321A	DIS_T/K_T_D_L	M_T_L	A_T_D_L
SDLD321B	DIS_T/K_T_D_L	M_T_L	A_T_D_L
SDLD321C	DIS_T/K_T_D_L	M_T_L	A_T_D_L

Hysteretic modeling of damping

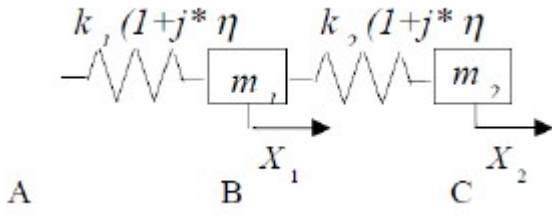

SDLD313

Title: System masses spring with 2 degrees of hysteretic freedom with damping

Documentation V: [V2.01.313]

Modelings:

SDLD313A	DIS_T/K_T_D_L	M_T_L
----------	---------------	-------

6.1.4 Other uses

Application of loading or boundary conditions specific.

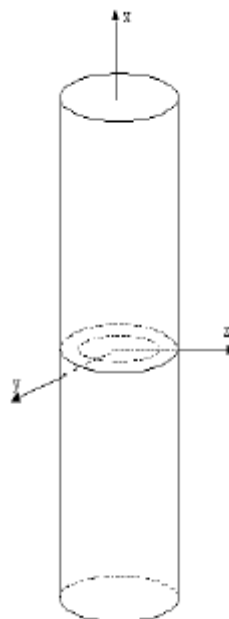

SSNV166

Title: Cylinder fissured under chargements multiples

Documentation V: [V6.04.166]

Modelings:

SSNV166A DIS_TR /K_TR_D_N M_TR_D_N

SSNV166B DIS_TR /K_TR_D_N M_TR_D_N

SSNV166C DIS_TR /K_TR_D_N M_TR_D_N

(worthless stiffness and mass)

In this model 3D, one applies a loading of torsion and inflection to the higher face of the cylinder via a mesh PO11 and a connection LIAISON_ELEM.

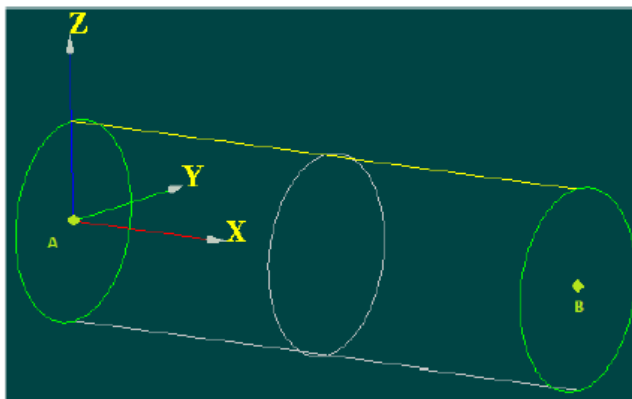

SDLL135

Title: Dynamic response of a embed-free beam-pipe.

Documentation V: [V2.02.135]

Modelings:

SDLL135F DIS_TR /K_TR_D_N M_TR_D_N
(worthless stiffness and mass)

In this model DKT , the nodes located in section A are dependent (LIAISON_ELEM) with a discrete element DIS_TR (mesh of the type not POI1 located in A) with 6 degrees of freedom, which is completely fixed for him.

Modeling of a model made up of nodes for the projection of results.

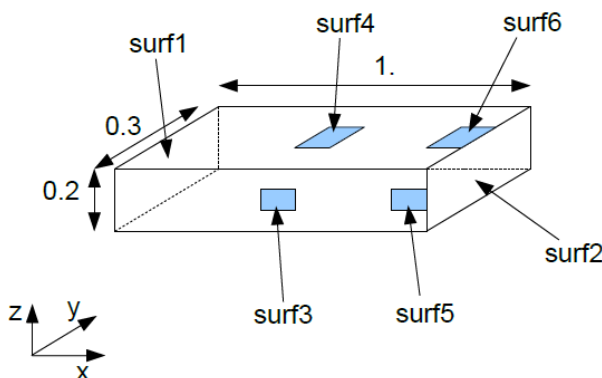

SDLV131

Title: Simulation of a gauge of deformation by the order OBSERVATION

Documentation V: [V2.04.131]

Modelings :

SDLV131A DIS_T
SDLV131B DIS_T
SDLV131C DIS_T
SDLV131D DIS_T

Digital creation of model for the comparison of experimental results:

- SDLS112B : Extrapolation of measurements on a model 2D (test of GARTEUR)
- SDLV122A : Extrapolation of local measurements on a complete model (3D) [V2.04.122] .

- SDLD104A/B : Extrapolation of local measurements on a complete model (discrete).

Taking into account of the contact (via operator `DEFI_CONTACT`) between two meshes `POI1` of worthless stiffness.

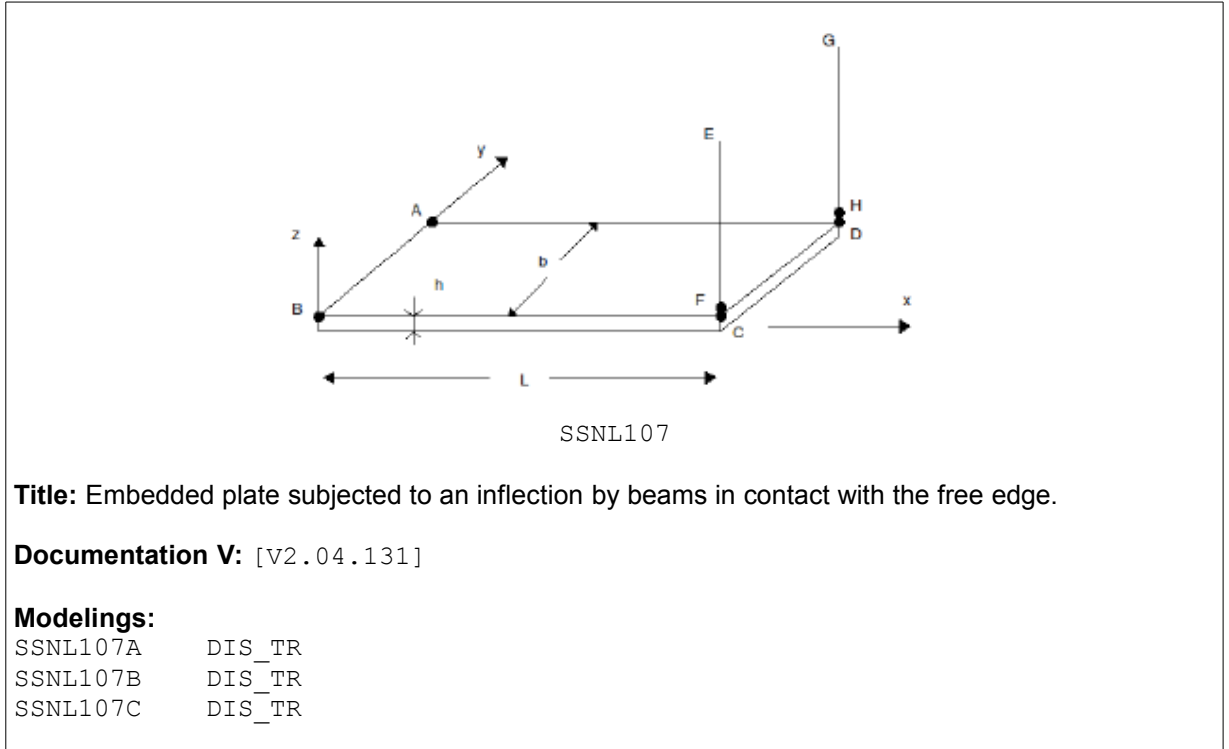

7 Bibliography

- 1 Operator CREA_MAILLAGE [U4.23.02].
- 2 Operator AFFE_MODELE [U4.41.01].
- 3 Operator DEFI_MATERIAU [U4.43.01].
- 4 Operator AFFE_CARA_ELEM [U4.42.01].
- 5 Operator AFFE_CHAR_MECA and AFFE_CHAR_MECA_F [U4.44.01].
- 6 Operator CALC_MATR_ELEM [U4.61.01].
- 7 Operator CALC_CHAMP [U4.81.04].
- 8 Operator POST_ELEM [U4.81.22].
- 9 Modelings DIS_T and DIS_TR [U3.11.02].
- 10 Modelings 2D_DIS_T and 2D_DIS_TR [U3.13.09].
- 11 Relations of behavior discrete elements [R5.03.17].
- 12 Law of behaviour of the assembly ASSE_CORN [R5.03.32].
- 13 Modeling of damping in linear dynamics [R5.05.04].
- 14 Note of modeling of the mechanical cushioning [U2.06.03].